

Quilter's FabriCalc™

Quilt Design and Fabric
Estimating Calculator
Model 8400

User's Guide

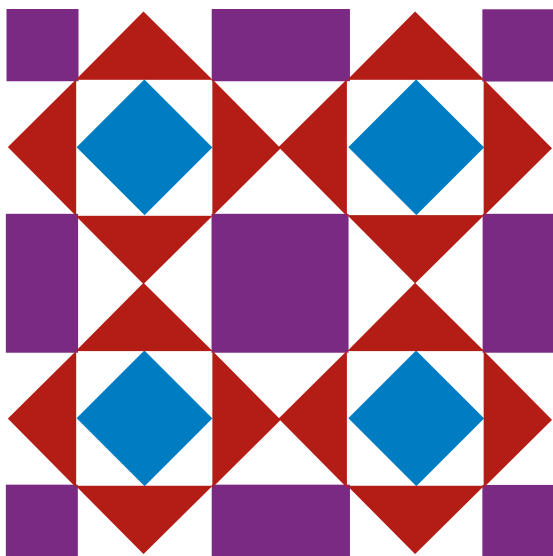

INTRODUCTION

The new *Quilter's FabriCalc* Design and Fabric Estimating Calculator is perfect for all of your design needs.

The *Quilter's FabriCalc* easily calculates your material yardage so you can focus on creativity.

Your Calculator Helps You Solve:

- *Quilt Fabric Yardage for any size or style of quilt, including:*
 - *Backing Yardage*
 - *Border Yardage (mitered or straight corners)*
 - *Drop Yardage (mitered or straight corners)*
 - *Binding Yardage*
- *Yardage for various sizes of Blocks, including Sashing, if needed.*
- *Yardage, cut sizes (including seam) and number of strips to cut for various sizes of Squares, including 1/2 Square and 1/4 Square Triangles.*
- *Yardage, cut sizes (including seam) and number of strips to cut for 45° and 60° Diamonds.*
- *Also calculates number of Squares or Diamonds that can be cut from any size of fabric you want to use – make the most of your “stash” of fabric.*
- *Easily keep track of how much fabric you need for various colors of fabrics; store up to six different types of fabrics.*

TABLE OF CONTENTS

INTRODUCTION

GETTING STARTED	1
Basic Operation and Entry Keys	1
Fabric Default Values	3
Yardage and Meterage Keys	4
Converting Fractional Yardage to Decimal Yardage	5
Converting Yardage to Meterage	5
Dimensional Measurement Unit Keys	6
Entering Linear Dimensions	6
Entering Area Dimensions.....	7
Additional Functions.....	8
CALCULATING QUILT YARDAGE	9
Top and Backing Yardage	12
Standard Quilt Sizes	13
Quilt Top Length, Top Width, Border and Drop	14
Multiple Borders	17
CALCULATING BLOCK YARDAGE	22
Blocks (Square-Shaped), Including Sashing	26
Blocks (Rectangular-Shaped), No Sashing	28
Calculating the Block's Diagonal	30
CALCULATING YARDAGE FOR SQUARES, TRIANGLES AND DIAMONDS	31
Number Entries	34
Length and Area Entries	34
Yardage Required for a Number of Squares	35
Number of Squares Calculated From Fabric ("Stash")	37
Number of Squares Calculated From Fabric (Length).....	39
Yardage Required for Corner and Side Triangles.....	40

FABRIC STORAGE	42
Storing Yardage for Multiple Fabrics	44
MEMORY OPERATION	46
Basic Cumulative Memory (M+)	
Example.....	47
CALCULATING COST OF MATERIAL	48
Fabric Cost Example	48
UNIT CONVERSIONS	49
Converting Fractional Inches to	
Decimal Inches	49
Converting Inches to Centimeters,	
Millimeters	49
Area Conversions.....	50
BASIC MATH	51
Adding Values	51
Subtracting Values	51
Multiplying Values	52
Dividing Values.....	53
Percentage Calculations	54
APPENDIX A — DEFAULT SETTINGS	55
Reset Function	55
APPENDIX B —	
PREFERENCE SETTINGS	56
How to Set Preferences	56
Accessing Preference Settings	56
APPENDIX C —	
IMPORTANT NOTES FOR OWNERS OF	
PREVIOUS FABRICALCS	58
APPENDIX D —	
OPERATING INSTRUCTIONS	62
Battery	62
Battery Replacement Instructions	62
APPENDIX E — ACCURACY, ERRORS	
AND AUTO SHUT-OFF	64
Accuracy/Errors	64
Auto Shut-Off	65
APPENDIX F - REPAIR AND RETURN	66
WARRANTY	67
INDEX	70

GETTING STARTED

Your calculator is designed to work with common fabric measurements for easy calculation of various quilt requirements.

Your calculator is defaulted to display the calculated results in fractional format. You can also set your calculator to display in decimal or metric format (see **Preference Settings** for details on how to change formats).

Basic Operation and Entry Keys

On/C — **On/Clear Key**

Turns on power. Pressing once clears the display. Pressing twice clears all temporary values.

Off — **Off Key**

Turns all power off, clearing all entered Quilt, Block, and Square values. Your calculator is also designed to shut itself off after about 8-12 minutes of non-use.



Arithmetic operation keys. See **Basic Math** section for details.



Four-function (+, −, ×, ÷) percent key. See **Percent Calculations** section for details.

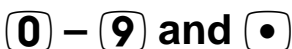

Keys used for entering digits.



Used to enter fractions. Fractions may be entered as proper ($1/2$, $1/3$, $1/4$, $1/8$) or improper ($7/6$, $9/3$). They will be displayed in $1/8$, $1/4$, $1/3$, or $1/2$ increments. You can also use  to toggle between fractional and decimal displays.



Used to convert between units of measure or access secondary functions.



Used to round decimal values to the nearest quilter's fraction. Also used to round yardage values up to the closest fractional value if the decimal yardage exceeds the closest fractional equivalent by 0.01 Yard. See Appendix C for details on Fractional Rounding.

Rcl

Used for recalling entered or stored values.

Fabric Default Values

These keys are used for storing values used for proper calculation of fabric Yardage.

Conv + — Seam

Stores the Seam width (default: 1/4 Inch). This value is used in the material functions for proper material calculations (e.g., **1 / 4 Inch Conv +**).

Conv 8 — Binding Cut

Stores the Binding Cut Width (default: 2 1/2 Inches). This value is used in the Binding calculation found in the Total Quilt Yardage function (e.g., **2 Inch 1 / 2 Conv 8**).

This value should be stored with seam allowance included in the stored value (no seam allowance adjustments are made to the Binding calculations).

Conv **—** — **Fabric Width**

Stores the Fabric Width (default: 40 Inches). This value is used in all of the material functions for providing the proper Yardage based on the stored Fabric Width (e.g., **4** **0** **Inch** **Conv** **—**).

Conv **÷** — **Backing +**

Stores the Backing Overage (default: 4 Inches). This value is used in the Backing calculation found in the Quilt Yardage function, and is added to all four sides of the quilt to accommodate the extra material needed for the quilting process (e.g., **4** **Inch** **Conv** **÷**).

Yardage and Meterage Keys

Ydg — **Yardage**

Enters or converts to *Yardage* (*linear Yards*). *Yardage* is based on the stored Fabric Width (default is 40 Inches). Also used with the **/** key for entering fractional *Yardage* values (e.g., **4** **Ydg** **1** **/** **2**).

Note: Repeated presses after **Conv** toggle between fractional and decimal values (e.g., **4** **Ydg** **1** **/** **2** **Conv** **Ydg** converts to 4.5 linear Yards (“yardage”); press **Ydg** again to return to fractional *Yardage*).

m — Meterage

Enters or converts to linear *Meters*. *Meterage* is based on the stored Fabric Width (default is 40 Inches, but you may store any Fabric Width desired e.g., 1 Meter).

Convert Fractional Yardage to Decimal Yardage

Convert 8-1/8 Yards to Decimal Yards. Then convert back to Fractional Yards.

KEYSTROKE	DISPLAY
On/C On/C	0.
8 Ydg 1 / 8	8-1/8 YD
Conv Ydg	8.125 YD
Conv Ydg	8-1/8 YD

Convert Yardage to Meterage

Convert 8-1/8 Yards to Meterage.

KEYSTROKE	DISPLAY
On/C On/C	0.
8 Ydg 1 / 8	8-1/8 YD
Conv m	7.430 M

Dimensional Measurement Unit Keys

The following keys are used for entering units of measure, with ease and accuracy:

Inch — **Inch**

Enters or converts to *Inches*. Also used with the **/** key for entering fractional Inch values (e.g., **9** **Inch** **1** **/** **2**).

Note: *Repeated presses after **Conv** toggle between fractional and decimal Inches (e.g., **9** **Inch** **1** **/** **2** **Conv** **Inch** converts to 9.5 Inch; press **Inch** again to return to Inch-Fractions).*

cm — **Centimeters**

Enters or converts to *Centimeters*.

Conv **9** — **Millimeters**

Enters or converts to *Millimeters*.

Entering Linear Dimensions

When entering fractional values for Inches, identify your entry by using the **Inch** key. Enter fractions by entering the numerator (top), pressing **/** (fraction bar key) and then the denominator (bottom). Press **On/C** after each example.

INCH

KEYSTROKE

5 Inch

5 **Inch**

5-1/2 Inches

5 **Inch** **1** **/** **2**

5.5 Inches

5 **.** **5** **Inch**

CENTIMETERS

KEYSTROKE

5 Centimeters **5** **cm**

5.5 Centimeters **5** **.** **5** **cm**

MILLIMETERS

KEYSTROKE

5 Millimeters **5** **Conv** **9**

5.5 Millimeters **5** **.** **5** **Conv** **9**

Entering Area Dimensions

You can enter or calculate area values for Inches, Centimeters, or Millimeters. For instance, if you are working with a piece of fabric that is 40 Inches x 10 Inches (400 sq. Inches), you can enter this area for use in the Square, Triangle, and Diamond functions (see Square sections for examples).

INCH

KEYSTROKE

400 sq. in. **4** **0** **0** **Inch** **Inch**

25.5 sq. in. **2** **5** **.** **5** **Inch** **Inch**

CENTIMETERS

KEYSTROKE

100 sq. cm **1** **0** **0** **cm** **cm**

25.5 sq. cm **2** **5** **.** **5** **cm** **cm**

MILLIMETERS

KEYSTROKE

100 sq. mm **1** **0** **0** **Conv** **9** **9**

25.5 sq. mm **2** **5** **.** **5** **Conv** **9** **9**

Note: Yardage and Meterage are linear functions, linked to Fabric Width. They do not allow entry of Square or Cubic Yards or Meters.

Additional Functions

Conv  — **Pi (π)**

Constant = 3.141593.

Conv  — **Access Preference Settings**

Used to access various customizable settings. See **Preference Settings** for details.

Conv  — **Clear All**

Clears all stored values, including Memory, and resets to default values (except Preference Settings which are retained).

***Note:** Use only when necessary, as it deletes all stored values.*

CALCULATING QUILT YARDAGE

The following keys are used to calculate Yardage including backing, binding, borders, and drops.

Top Width

Enters finished Width of quilt top for calculating the top Yardage of material required.

Top Length

Enters finished Length of quilt top for calculating top Yardage required. A second consecutive press of **Top Length** calculates the diagonal of the finished top quilt based on the entered Top Width and Top Length.

Border

Enters the finished Border Width (4-sided border). This value then calculates, upon repeated presses, the following:

<u>Press</u>	<u>Result</u>
1	Border Yardage
2	Number of Strips (to cut for the Border)
3	Border Strip Cut Width

Note: Border values are based on the Corner (Miter vs. Straight) Preference Setting (default: Mitered Corners). See **Preference Settings** for details.

Drop

Enters the finished Drop Width (3-sided drop). This value then calculates, upon repeated presses, the following:

<u>Press</u>	<u>Result</u>
1	Drop Yardage
2	Number of Strips (to cut for the Border)
3	Drop Strip Cut Width

Note: Drop values are based on the Corner (Miter vs. Straight) Preference Setting (default: Mitered Corners). See **Preference Settings** for details.

Quilt Ydg

Consecutive presses of this key calculate:

<u>Press</u>	<u>Result</u>
1	Top Quilt Yardage
2	Backing Yardage*
3	Border Yardage**
4	Number of Strips to cut for Border**
5	Border Strip Cut Width**
6	Drop Yardage**
7	Number of Strips to cut for Drop**
8	Drop Strip Cut Width**
9	Binding Yardage***

<u>Press</u>	<u>Result</u>
10	Quantity of Strips to cut for the Binding***
11	Stored Binding Strip Cut Width***

Note: Continued presses of  will repeat above sequence.

**Backing Yardage does not include repeats.*

***If Border or Drop is not entered, these values are not displayed in the above Total Quilt Yardage list.*

****All calculated items include adjustments for seam allowance, except for Binding (it is assumed the seam allowance is included in the stored Binding cut value used for calculating Binding Yardage and number of strips).*

Note: Entries of Top Width, Top Length, Border, and Drop are semi-permanent entries; that means, they do not clear until you turn off your calculator or until you enter a new value. You can enter zero to clear these values if you have previously stored values.

Top and Backing Yardage

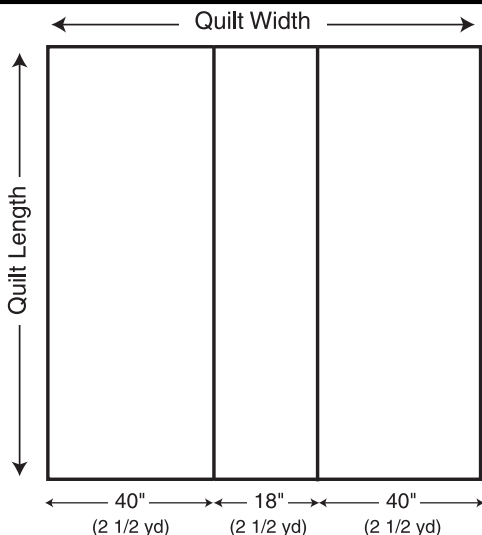

Top and Backing Yardage are calculated based on a linear, or “running” method for laying out the quilt. This means the Length of each strip (or “run”) is based on the Length of quilt, and the number of runs needed is based on the Width of the quilt.

In the diagram above, the layout shows three runs (two runs that are 40” wide and one run that is 18” wide). The Quilter’s FabriCalc will actually calculate Yardage for three runs that are each 40” wide (2 1/2 Yards each), even though the actual finished Width of the runs may vary. It is calculated this way to allow plenty of material to lay out your top or backing. Each run is uncut along the

(Cont’d)

(Cont'd)

Length of the run (e.g., the strips run the Length quilt without having to piece material together).

If your top or backing strips are laid out parallel to your Width, you can switch your values on the Top Width and Top Length keys in order to calculate the correct top and backing Yardage and strip cut values for this orientation (e.g., re-enter Top Width as Top Length, and Top Length as Top Width).

NOTE: *If your quilt has a Drop included and you need to calculate Yardage for strips that are laid out widthwise, the Drop and Backing will not be calculated correctly once you switch your Top Width and Top Length values since the Drop does not change to fit this different orientation. You will need to calculate your Drop before switching your Top Width and Top Length values. Then switch (re-enter) your Top Width and Top Length values and calculate your Top Quilt Yardage. To properly calculate your Backing with a Drop, you will need to add the Drop Width to the Top Width and Top Length values and re-calculate your Backing Yardage.*

Standard Quilt Sizes

QUILT TYPE	MATTRESS SIZE
Crib	23" x 46"
Twin	39" x 75"
Full	54" x 75"
Queen	60" x 80"
King	76" x 80"
California King	72" x 84"

Quilt Top Length, Top Width, Border and Drop

Find the Top Yardage of a standard queen-size quilt (80 Inches Length x 60 Inches Width), with a finished Border Width of 4 Inches, and a finished Drop Width of 18 Inches.

Then calculate the following values:

- *Top Yardage*
- *Backing Yardage*
- *Border Yardage, number of strips and strip cut Width*
- *Drop Yardage, number of strips and strip cut Width*
- *Binding Yardage, number of strips and strip cut Width (Note: this is Strip Binding, not Bias Binding)*

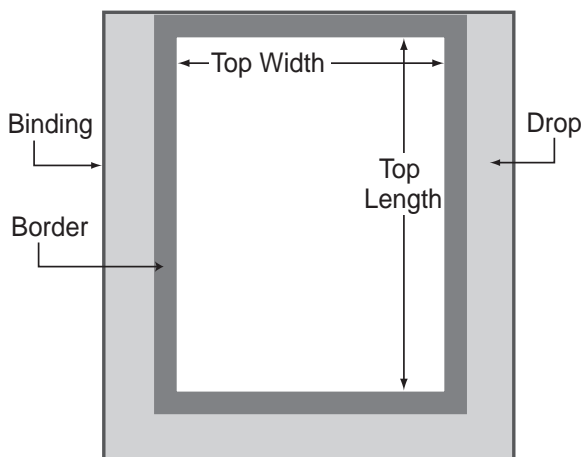

Note: You will notice the Drop is outside of the Border (this is typical for a standard bedspread). If you need your Drop to be included inside of the Border, add your Drop values to your Top Width and Top Length (do not enter Drop separately).

KEYSTROKE

DISPLAY

1. Enter finished top quilt measurements:

On/C **On/C** **0.**

6 **0** **Inch** **Top Width** **WIDTH 60 INCH**

8 **0** **Inch** **Top Length** **LNGLTH 80 INCH**

2. Enter finished Border Width:

4 **Inch** **Border** **BORDR 4 INCH WIDTH**

3. Enter finished Drop Width

1 **8** **Inch** **Drop** **DROP 18 INCH WIDTH**

4. Find top Quilt Yardage:

Quilt Ydg **TOP 4-1/2 YD**

5. Find backing Yardage:

Quilt Ydg **BKNG 9-1/2 YD**

6. Find Border Yardage:

Quilt Ydg ****** **BORDR 1 YD**

7. Find Border number of strips:

Quilt Ydg ****** **BORDR 8. QTY STRIPS**

8. Find Border cut Width:

Quilt Ydg ****** **BORDR 4-1/2 INCH CUT WIDTH STRIPS**

(Cont'd)

(Cont'd)

9. Find Drop Yardage:

**Quilt
Ydg*****

DROP 4-5/8 YD

10. Find Drop number of strips:

**Quilt
Ydg*****

DROP 9. QTY STRIPS

11. Find Drop strip cut Width:

**Quilt
Ydg*****

DROP 18-1/2 INCH CUT WIDTH STRIPS

12. Find binding Yardage:

**Quilt
Ydg**

BNDNG 0-7/8 YD

13. Find binding number of strips:

**Quilt
Ydg**

BNDNG 11. QTY STRIPS

14. Display stored binding strip cut Width:

**Quilt
Ydg**

BNDNG 2-1/2 INCH CUT WIDTH

*Continued presses of **Quilt
Ydg** will repeat above sequence.

**Border values are not displayed if Border is not entered.

***Drop values are not displayed if Drop is not entered.

Multiple Borders

You are making a queen size quilt (60" x 80" mattress size) that has three borders. The inner border (Border #1) is 2 Inches wide, the middle border (Border #2) is 4 Inches, and the outer border (Border #3) is 6 Inches wide. How much material do you need to make each border? How much material do you need for the backing and binding (including all borders)?

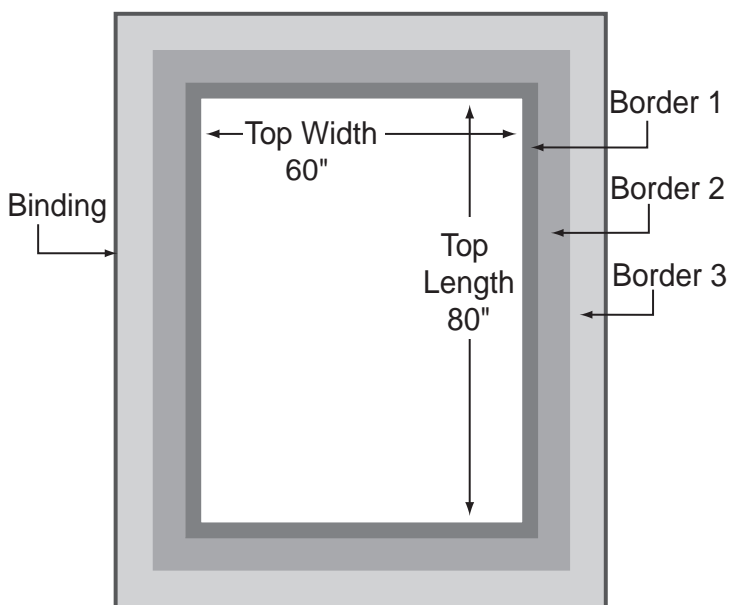

Step 1: *Enter the quilt top Length and Width and border finished Width, and then find the Yardage required for Border #1:*

(Cont'd)

(Cont'd)

KEYSTROKE

DISPLAY

1. Enter top Length, Width, and Border #1 finished Width:

On/C	On/C				0.
6	0	Inch	Top Width		WIDTH 60 INCH
8	0	Inch	Top Length		LNGLTH 80 INCH
2	Inch	Border			BORDR 2 INCH WIDTH

2. Find Yardage required for Border #1, quantity of strips to cut and strip cut Width:

Border		BORDR 0-5/8 YD
Border		BORDR 8. QTY STRIPS
Border	BORDR 2-1/2 INCH CUT WIDTH STRIPS	

Step 2: Now enter Border #2 finished Width (continuing from Step 1 above) and find the Yardage required for Border #2. Since this border is going around Border #1, you will need to re-enter the Top Width and Top Length values including the finished Width of Border #1. Add two Inches to each of the Top Width and Top Length and re-enter your Top Width and Top Length:

KEYSTROKE**DISPLAY**

1. Enter new Top Width and Top Length values:

On/C	On/C							0.
6	0	Inch	+	4	Inch	=		64 INCH
Top Width								WIDTH 64 INCH
8	0	Inch	+	4	Inch	=		84 INCH
Top Length								LNPTH 84 INCH

2. Enter Border #2 finished Width:

4	Inch	Border		BORDR 4 INCH WIDTH
----------	-------------	---------------	--	---------------------------

3. Find Yardage required for Border #2, quantity of strips to cut and strip cut Width:

Border		BORDR 1-1/8 YD
Border		BORDR 9. QTY STRIPS
Border	BORDR 4-1/2 INCH CUT WIDTH STRIPS	

Step 3: Now enter Border #3 finished Width (continuing from Step 2 above) and find the Yardage required for Border #3. You will need to re-enter your Top Width and Top Length values to include the finished Width of Border #2. Recalling your previously entered Top Width and Length values from Step 2, add four Inches to each side of the Top Width and Top Length to account for Border #2, and re-enter your Top Width and Top Length values:

(Cont'd)

(Cont'd)

KEYSTROKE

DISPLAY

1. Recall existing Top Width and Top Length values, add the finished Width of Border #2 to each side in order to calculate your new Top Width and Top Length, then re-enter these values:

On/C On/C	0.
Rcl Top Width	WIDTH 64 INCH
+ 8 Inch =	72 INCH
Top Width	WIDTH 72 INCH
Rcl Top Length	LNPTH 84 INCH
+ 8 Inch =	92 INCH
Top Length	LNPTH 92 INCH

2. Enter Border #3 finished Width:

6 Inch Border	BORDR 6 INCH WIDTH
------------------------------------	---------------------------

3. Find Yardage required for Border #3, quantity of strips to cut and strip cut Width:

Border	BORDR 1-7/8 YD
Border	BORDR 10. QTY STRIPS
Border	BORDR 6-1/2 INCH CUT WIDTH STRIPS

Step 4: Find the Backing and Binding Yardage to finish your quilt. Now that you have your outside Border Width entered, you can calculate your over-all quilt values:

KEYSTROKE

DISPLAY

1. Calculate the top quilt Yardage, Backing, and Binding requirements:

Quilt Ydg *	TOP 5-1/8 YD
Quilt Ydg	BKNG 9-1/3 YD
Quilt Ydg **	BORDR 1-7/8 YD
Quilt Ydg **	BORDR 10. QTY STRIPS
Quilt Ydg **	BORDR 6-1/2 INCH CUT WIDTH STRIPS
Quilt Ydg	BNDNG 0-3/4 YD
Quilt Ydg	BNDNG 10. QTY STRIPS
Quilt Ydg	BNDNG 2-1/2 INCH CUT WIDTH

*Your top quilt Yardage includes the finished Widths of Border #1 and #2. If you need to find the top quilt Yardage that includes all three Borders, re-enter your Top Width and Top Length values to include the finished Widths of all three Borders, clear any any stored Border Width **0**

Border, and then press the **Quilt Ydg** key.

**Border Yardage requirements are displayed if a value has been entered for Border (in this case, a 6 Inch Border).

CALCULATING BLOCK YARDAGE

The following keys are used to calculate the Yardage of material required for a number of Blocks.

Block Size

Enters the Block Width for calculating Total Block Yardage via the **Block Ydg** key. A second consecutive press of **Block Size** also displays the diagonal of the Block.

If no Block Height is entered, the entered Block is assumed to be square (e.g., **4** **Inch** **Block Size** stores a 4 x 4 Block to calculate Block values).

Conv **Block Size** — Block Height

Enters the Block Height for rectangular-shaped Blocks. This value does not need to be entered if the Block is square, as explained above. Repeated presses of **Block Size** displays Block Width, Block Height, and Block Diagonal.

If you enter a Block Height, this value remains until you enter a **Block Size** value again. You will need to re-enter a Block Height if you do not want to use the entered **Block Size** as your Block Height.

Rectangular Block Quick-entry method: You can enter a 4 x 6 Inch Block by simply entering the Block Width and Height values as **4** **X** **6** (Inches are assumed). For instance, enter the Block Width value, followed by the **X** key, and then the Block Height value, and then press the **Block Size** key (e.g. **4** **X** **6** **Block Size** stores the Block Size of 4 Inch Width by 6 Inch Height).

#Across

Enters the number of Blocks that will be placed across the Width of the quilt (e.g., the number of Blocks in one row). Default is one (1) Block Across (if user does not enter this value).

#Down

Enters the number of Blocks that will be placed down the Length of the quilt (e.g., the number of Blocks in one column). Default is one (1) Block Down (if user does not enter this value).

Sashing

Enters the finished Sashing Width (e.g., in inches). This key calculates, upon repeated presses, the following values:

<u>Press</u>	<u>Result</u>
1	Sashing Yardage
2	Number of Strips (to cut for the Sashing)
3	Sashing Strip Cut Width

Note: *Sashing is calculated, by default, to include Sashing surrounding the perimeter of the Blocks (see **Preference Settings** for details) in addition to the Sashing between Blocks. You may select not to include the Sashing surrounding the Blocks and only calculate the Sashing between Blocks (see figure below). See **Preference Settings** for how to change this Sashing Preference Setting.*

Consecutive presses of this key calculate:

<u>Press</u>	<u>Result</u>
1	Total Block Yardage
2	Number of Blocks
3	Number of Strips
4	Block Strip Cut Width
5	Total Sashing Yardage*
6	Number of Strips (to cut for the Sashing)*
7	Sashing Strip Cut Width*

Note: Continued presses of  will repeat above sequence.

*Sashing values do not display if Sashing is zero.

Note: Entries of Block size, number of Blocks across, number of Blocks down, and Sashing are semi-permanent entries; that means, they do not clear until you turn off your calculator or until you enter a new value. You can enter zero for Sashing if you do not want Sashing included in the Block Yardage calculation.

Blocks (Square-Shaped), Including Sashing

Find the total Yardage of material required for Blocks if the finished Block Width is 10 Inches and the quilt will have 3 Blocks across and 4 Blocks down. The finished Sashing Width is 2 Inches.

Then calculate the following values:

- *Number of Blocks*
- *Number of Block strips*
- *Block cut Width*
- *Sashing Yardage*
- *Number of Sashing strips*
- *Sashing cut Width*

Blocks Across

	1	2	3
# Blocks Down	2		
	3		
	4		

Note: *This example includes Sashing around the perimeter of the Blocks, based on the Sashing Preference Setting. To change your Sashing Preference settings to exclude Sashing around the Block perimeter, see **Appendix B** for details on how to set this.*

KEYSTROKE**DISPLAY**

1. *Enter finished Block Width in Inches:*
On/C **On/C** **0.**
1 **0** **Inch** **Block Size** **SIZE 10 INCH**
2. *Enter Number of Blocks Across:*
3 **#Across** **ACRSS 3. QTY**
3. *Enter Number of Blocks Down:*
4 **#Down** **DOWN 4. QTY**
4. *Enter Sashing (finished) Width:*
2 **Inch** **Sashing** **SASH 2 INCH WIDTH**
5. *Find total Block Yardage:*
Block Ydg **TOTAL 1-1/4 YD**
6. *Find total number of Blocks:*
Block Ydg **TOTAL 12. QTY**
7. *Find the number of Block strips:*
Block Ydg **TOTAL 4. QTY STRIPS**
8. *Find Block cut Width:*
Block Ydg **TOTAL 10-1/2 INCH CUT WIDTH STRIPS**
9. *Find Sashing Yardage:*
Block Ydg **** SASH 0-3/4 YD**
10. *Find number of Sashing strips:*
Block Ydg **** SASH 10. QTY STRIPS**
11. *Find Sashing cut Width:*
Block Ydg **** SASH 2-1/2 INCH CUT WIDTH STRIPS**

(Cont'd)

(Cont'd)

Note: Continued presses of **Block Ydg** will repeat above sequence.

****Sashing values are not displayed if Sashing is not entered.**

Note: You can also view Sashing calculations with multiple key presses of **Sashing** upon entry of the Sashing Width.

Blocks (Rectangular-Shaped), No Sashing

Find the total Yardage of material required for Blocks if you will have 3 Blocks Across and 4 Blocks Down. The Block Width is 10 Inches and the Block Height is 8 Inches. There is no Sashing.

Then calculate the following values:

- *Total number of Blocks*
- *Total number of Block strips*
- *Block cut Width*

Blocks Across

	1	2	3
# Blocks Down	2		
	3		
	4		

KEYSTROKE

DISPLAY

1. Enter finished Block Width in Inches:
 On/C On/C 0.
 1 0 Inch Block Size SIZE 10 INCH
2. Enter Block Height in Inches:
 8 Inch Conv Block Size HGHT 8 INCH
3. Enter number of Blocks Across:
 3 #Across ACRSS 3. QTY
4. Enter number of Blocks Down:
 4 #Down DOWN 4. QTY
5. Clear previously entered Sashing:
 0 Sashing* SASH 0 INCH WIDTH
6. Find total Block Yardage:
 Block Ydg TOTAL 0-7/8 YD
7. Find total number of Blocks:
 Block Ydg TOTAL 12. QTY
8. Find the number of Block strips:
 Block Ydg TOTAL 3. QTY STRIPS
9. Find Block cut Width:
 Block Ydg** TOTAL 10-1/2 INCH CUT WIDTH STRIPS

*Sashing values are not displayed since Sashing was cleared.

Continued presses of **Block Ydg will repeat the sequence above.

Note: You may also enter a Block's size by entering the Length times Width, then press the **Block Size** key. For example, if you have a 10 Inch (Width) x 8 Inch (Height) Block size, enter it as **1 0 X 8 Block Size** (10 INCH BLOCK WIDTH is displayed). See following example.

Calculating the Block's Diagonal

Find the Block's diagonal if the Block size is ten Inches wide x eight Inches high.

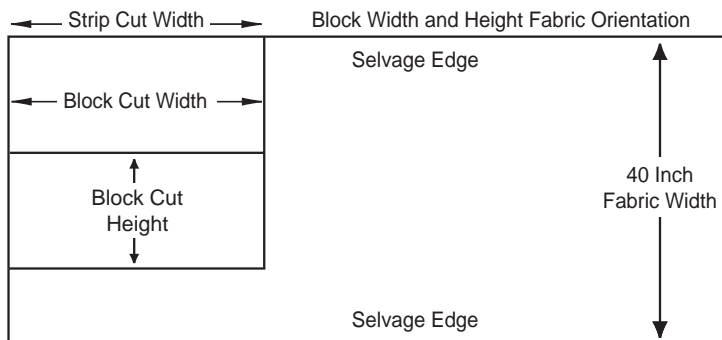

KEYSTROKE

DISPLAY

1. *Enter finished Block size in Inches:*

On/C **On/C** **0.**
1 **0** **X** **8** **Block Size*** **WIDTH 10 INCH**
Block Size **HGHT 8 INCH**

2. *Find diagonal of Block:*

Block Size **DIAG 12-3/4 INCH**

**You may also calculate the diagonal of a Square or rectangular Block.*

CALCULATING YARDAGE FOR SQUARES, TRIANGLES, AND DIAMONDS

The following keys are used to calculate the Yardage required for Squares, 1/2 Square Triangles, 1/4 Square Triangles, and Diamonds (45° and 60°).

Additionally, these keys can also be used to calculate the quantity that can be cut from a given size of fabric. For example, if you have a Yard of fabric, you can calculate how many Squares, Triangles, or Diamonds can be cut from that piece of fabric.

Note: These are “smart” keys that allow you to enter a unitless value, a Length, or an area. If a Length is entered, the fabric area is calculated based on the stored Fabric Width and they calculate a quantity. If a unitless value is entered, this entry is assumed to be the Number of Squares and they calculate the Yardage required.

Square Size

Enters the Length of a Square's size (e.g., enter **2** **Inch** **Square Size** to store a 2 Inch x 2 Inch Square size).

Note: Square size is a semi-permanent value (that means, it does not clear until you turn off your calculator, or until you enter a new value).

Conv **Square Size**

Displays or enters the diagonal of a Square (e.g., **7** **Inch** **Conv** **Square Size** enters a seven Inch diagonal).

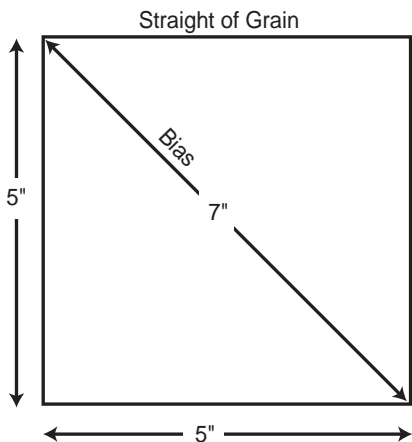

Squares

Calculates the Yardage required based on an entered number of Squares. Also calculates the number of Squares that can be cut from an entered amount (Length or Area) of fabric.

1/2 Sq

Calculates the Yardage required based on an entered number of 1/2 Square Triangles. Also calculates the number of 1/2 Square Triangles that can be cut from an entered amount (Length or Area) of fabric.

1/4 Sq



Calculates the Yardage required based on an entered number of 1/4 Square Triangles. Also calculates the number of 1/4 Square Triangles that can be cut from an entered amount (Length or Area) of fabric.

45°



Calculates the Yardage required based on an entered number of 45° Diamonds. Also calculates the number of 45° Diamonds that can be cut from an entered amount (Length or Area) of fabric.

Conv



Pressing **Conv** then **45°** calculates the Yardage required based on an entered number of 60° Diamonds. Also calculates the number of 60° Diamonds that can be cut from an entered amount (Length or Area) of fabric.

Number Entries

Consecutive presses of the  button

  or  keys calculate:

<u>Press</u>	<u>Result</u>
1	Fabric Yardage
2	Number of Strips
3	Strip Cut Width
4	Diamond Cut Length (Diamonds only)

Length and Area Entries

Consecutive presses of the  button

  or  keys calculate:

<u>Press</u>	<u>Result</u>
1	Quantity of Squares, Triangles, or Diamonds
2	Number of Strips
3	Strip Cut Width
4	Diamond Cut Length (Diamonds only)

Yardage Required for a Number of Squares

Find the Yardage of fabric needed to make 25 six-Inch Squares. Then calculate the total number of Strips and the Strip cut Width.

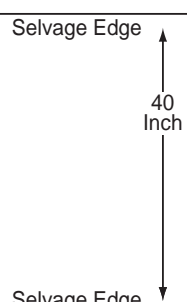
Strip Cut Width: 6-1/2 Inch					Fabric Layout	
1	7	13	19	25	Selvage Edge  40 Inch Selvage Edge	
2	8	14	20			
3	9	15	21			
4	10	16	22			
5	11	17	23			
6	12	18	24			

KEYSTROKE

DISPLAY

1. Enter finished Square size in Inches:

On/C **On/C**

0.

6 **Inch** **Square Size**

SIZE 6 INCH

2. Enter number of Squares and calculate Yardage:

2 **5** **Squares**

TOTAL 1 YD

3. Calculate number of Strips:

Squares

TOTAL 5. QTY STRIPS

4. Calculate cut Width of Strips:

Squares

TOTAL 6-1/2 INCH CUT WIDTH STRIPS

(Cont'd)

(Cont'd)

Note: You may also calculate 1/2 Square Triangles, 1/4 Square Triangles, 45° Diamonds, and 60° Diamonds based on an entered Square Size and quantity. Diamonds will also display the Diamond Cut Length, for easy measuring and cutting of Diamonds.

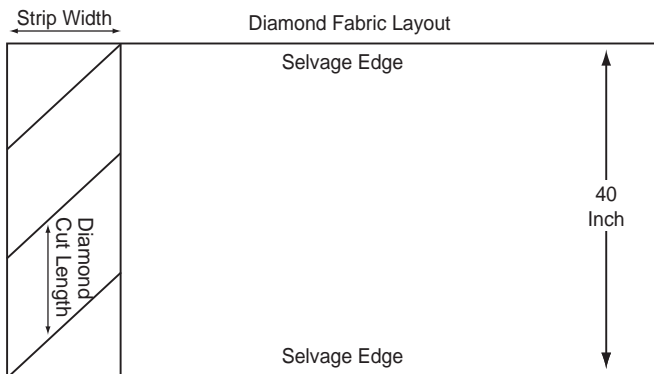

Number of Squares Calculated From Fabric (“Stash”)

Find the number of four-Inch squares that can be cut from an 18 x 40 Inch piece of fabric. Then calculate the total number of Strips and Strip cut Width.

KEYSTROKE

DISPLAY

1. *Enter finished Square size in Inches:*

On/C **On/C** **0.**
4 **Inch** **Square Size** **SIZE 4 INCH**

2. *Calculate area of fabric:*

1 **8** **Inch** **×** **4** **0** **Inch** **=**
720. SQ INCH

3. *Calculate number of Squares:*

Squares **TOTAL 32. QTY**

4. *Calculate number of Strips:*

Squares **TOTAL 4. QTY STRIPS**

5. *Calculate cut Width of Strips:*

Squares
TOTAL 4-1/2 INCH CUT WIDTH STRIPS

Note: *The Square calculations are based on the stored fabric Width (in this example it is based on the default of 40 Inches). If you have a different fabric Width (e.g., 18 Inch Width x 22 Inch Height), you must change your “scrap” Width (e.g., 18 Inches) as fabric Width. Keep in mind your fabric Width is used for all your quilt, Block and Square calculations, so you will want to change it back to the standard fabric Width for accurate calculations See example on the following page.*

(Cont'd)

(Cont'd)

KEYSTROKE	DISPLAY
<i>1. Store new fabric Width:</i>	
On/C On/C	0.
1 8 Inch Conv —	
	FABRIC WIDTH 18 INCH
<i>2. Enter finished Square size:</i>	
4 Inch Square Size	SIZE 4 INCH
<i>3. Calculate area of fabric:</i>	
1 8 Inch X 2 2 Inch =	
	396. SQ INCH
<i>4. Calculate number of Squares:</i>	
Squares	TOTAL 16. QTY
<i>5. Calculate number of Strips:</i>	
Squares	TOTAL 4. QTY STRIPS
<i>6. Calculate cut Width of strips:</i>	
Squares	TOTAL 4-1/2 INCH CUT WIDTH STRIPS
<i>7. Return fabric Width to default 40 Inch Width fabric:</i>	
4 0 Inch Conv —	
	FABRC WIDTH 40 INCH

Number of Squares Calculated From Fabric (Length)

Find the number of 4-1/2 Inch (finished) Squares that can be cut from three Yards of fabric. Then calculate the total number of Strips to cut and the Strip cut Width.

KEYSTROKE

DISPLAY

1. *Enter finished Square Size in Inches:*

On/C **On/C** **0.**
4 **◦** **5** **Inch** **Square Size** **SIZE 4.5 INCH**

2. *Enter Length of fabric and calculate number of Squares:*

3 **Ydg** **Squares** **TOTAL 168. QTY**

3. *Calculate number of strips:*

Squares **TOTAL 21. QTY STRIPS**

4. *Calculate cut Width of strips:*

Squares **TOTAL 5 INCH CUT WIDTH STRIPS**

Yardage Required for Corner and Side Triangles

You are making a quilt with 10 Inch blocks. You need to find the cut size of the corner and side triangles and the Yardage requirements for each. First calculate (1/2 square) triangles' (A) cut size and Yardage requirements, then calculate the side (1/4 square) triangles' (B) cut size and Yardage requirements.

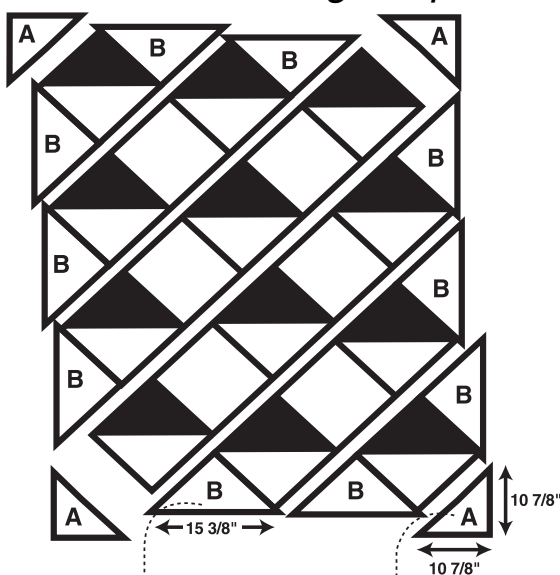

Side Triangles

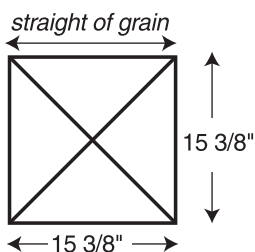

Corner Triangles

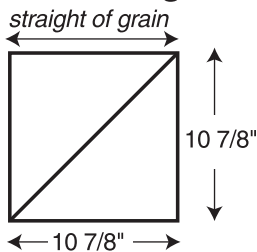

Step 1: Find the corner triangle (A) square cut-size and Yardage required.

KEYSTROKE	DISPLAY
-----------	---------

1. Enter finished Square size:

On/C	On/C	0.
1	0	SIZE 10 INCH
Inch	Square Size	

2. Enter number of corners and calculate Yardage of 1/2 Square Triangles:

4	1/2 Sq	HALF \triangle 0-1/3 YD
----------	---------------	---

3. Calculate number of strips to cut for the corners:

1/2 Sq	HALF \triangle 1. QTY STRIPS
---------------	--

4. Calculate strip cut Width:

1/2 Sq	10-7/8 INCH CUT WIDTH STRIPS
---------------	-------------------------------------

Step 2: Find the side triangle (B) square cut-size and Yardage required.

KEYSTROKE	DISPLAY
-----------	---------

1. Enter finished Square size:

On/C	On/C	0.
1	0	SIZE 10 INCH
Inch	Square Size	

2. Find the diagonal of the finished Square size:

Square Size	DIAG 14-1/8 YD
--------------------	-----------------------

(Cont'd)

(Cont'd)

3. Enter the diagonal as the new finished Square size:

= **Square Size** **SIZE 14-1/8 INCH**

4. Enter number of sides and calculate Yardage for side triangles:

1 **0** **1/4 Sq** **QTR** **△** **0-7/8 YD**

5. Calculate number of strips:

1/4 Sq **QTR** **△** **2. QTY STRIPS**

6. Calculate strip cut Width:

1/4 Sq **15-3/8 INCH CUT WIDTH STRIPS**

FABRIC STORAGE

Your calculator has six individual, cumulative registers for storing up to six different types of material Yardages. You can easily calculate various Yardage requirements for each type of fabric you are working with and store them in the fabric registers. This provides the flexibility of storing various Yardages for a particular fabric.

In addition, the total of these storage registers is viewable via the Total Fabric function. You can easily view your accumulated fabric Yardage so you know how much material you will need to complete your entire quilt project.

Conv **1** — Fabric 1

Adds the displayed value to Fabric 1.
Pressing **Rcl** **1** displays the value stored in Fabric 1.

Conv **2** — Fabric 2

Adds the displayed value to Fabric 2.
Pressing **Rcl** **2** displays the value stored in Fabric 2.

Conv **3** — Fabric 3

Adds the displayed value to Fabric 3.
Pressing **Rcl** **3** displays the value stored in Fabric 3.

Conv **4** — Fabric 4

Adds the displayed value to Fabric 4.
Pressing **Rcl** **4** displays the value stored in Fabric 4.

Conv **5** — Fabric 5

Adds the displayed value to Fabric 5.
Pressing **Rcl** **5** displays the value stored in Fabric 5.

Conv **6** — Fabric 6

Adds the displayed value to Fabric 6.
Pressing **Rcl** **6** displays the value stored in Fabric 6.

Conv **0** — Total Fabric

Displays the accumulated value from the Fabric 1-6 keys.

Conv **7** — Clear Fabric

Clears all values in the Fabric Storage registers (Fabric 1-6).*

* You may also enter zero to clear individual fabric register (e.g., **0** **Conv** **1**).

Storing Yardage for Multiple Fabrics

Your quilt consists of three different colors of fabric for the following five-Inch squares:

<u>Fabric</u>	<u>Quantity</u>
1 (Red)	10 Squares
2 (Blue)	25 1/2 Square Triangles
3 (White)	50 1/4 Square Triangles

Find the Yardage for each color of fabric and store these into the Fabric 1-3 registers. Then find the total, accumulated Yardage.

(Cont'd)

(Cont'd)

KEYSTROKE	DISPLAY
-----------	---------

1. Enter finished Square size in Inches:

On/C	On/C	0.	
5	Inch	Square Size	SIZE 5 INCH

2. Enter number of Squares for Fabric 1 and calculate Yardage:

1	0	Squares	TOTAL 0-1/3 YD
Conv	1		FAB-1 0-1/3 YD

3. Enter number of 1/2 Square triangles for Fabric 2 and calculate Yardage:

2	5	1/2 Sq	HALF 0-1/2 YD
Conv	2		FAB-2 0-1/2 YD

4. Enter number of 1/4 Square triangles for Fabric 3 and calculate Yardage:

5	0	1/4 Sq	QTR 0-5/8 YD
Conv	3		FAB-3 0-5/8 YD

5. View total Yardage of all three fabrics:

Conv	0	TOTAL 1-1/3 YD
-------------	----------	-----------------------

6. Clear stored fabric values:

Conv	7	“CLEAR FABrIC” 0.
-------------	----------	--------------------------

MEMORY OPERATION

Your calculator has a standard, cumulative memory **M+** function that is separate from the individual Fabric storage keys (FAB-1 through FAB-6) identified in the Fabric Storage section.

You can store values of the same dimension (unitless values that are added to existing linear or area values will assume the previously stored dimension).

You can recall stored values, calculate the average of all the stored values, and display the total number of entries that have been stored in memory.

M+ — Memory Plus

Adds any displayed number, dimensioned or unitless, to the semi-permanent, cumulative Memory.

Conv **M+** — Memory Minus

Subtracts the displayed value from the cumulative value stored in memory.

Rcl **M+** — Memory Recall

Displays the following values:

1. Cumulative value stored in memory.
2. Average of all entries in M+ register.
3. Number of entries that have been stored in the M+ register.

Rcl **Rcl** — Memory Recall/Clear

Displays and clears the value stored in memory.

Conv **Rcl** — Clear Memory

Clears the cumulative Memory without disturbing the existing display.

Note: *Semi-permanent means the value is cleared when the calculator is shut off. Memory is also cleared when a **Clear All** (**Conv** **X**) is performed, but use this with caution as it clears other stored values, as well.*

Basic Cumulative Memory (M+)

Example

Store 100 into M+, add 200, and then subtract 50. Recall the Memory total, Average, and Count. Then clear the Memory.

KEYSTROKE	DISPLAY
1 0 0 M+	M+ 100. M
2 0 0 M+	M+ 200. M
5 0 Conv M+	M- 50. M
Rcl M+	TOTAL 250. M
M+	AVG 83.33333 M
M+	COUNT 3. M
Rcl Rcl	TOTAL 250.

Note: *To Clear Memory (M+):*

1) Press **Rcl** **Rcl**;

2) **Conv** **Rcl**; or

3) Turn off the calculator.

CALCULATING COST OF MATERIAL

The Cost function provides the total cost for material, based on a stored unit cost (e.g., dollar per Yard in US Display Mode, and dollar per Meter in Metric Display Mode) and an entered quantity of material.

Fabric Cost Example

Find the Yardage for 20 five-Inch Squares. How much will the material cost if the material is \$9.99 per Yard?

First, calculate the Yardage required to make ten Squares. Then calculate the total fabric cost.

KEYSTROKE

DISPLAY

1. Enter the dollar per Yard:

On/C **On/C** **0.**
9 **.** **9** **9** **Conv** **=** **\$/YD 9.99**

2. Enter finished Square Size in inches:

5 **Inch** **Square Size** **SIZE 5 INCH**

3. Enter number of Squares and calculate Yardage:

2 **0** **Squares** **TOTAL 0-1/2 YD**

4. Calculate the Total Cost of Fabric:

Conv **=** **TTL\$ 5.00**

Note: Any unitless number entry into **Conv** **=** stores the Cost per Yard (if in Metric Mode, it stores the Cost per Meter). Once you have a value stored in Cost, you can then enter in your Yardage (or Meterage) to find the total cost per Yard (or Meter).

UNIT CONVERSIONS

You may enter Lengths in Inches, Centimeters, or Millimeters, and convert between these units. You may also enter in an area (e.g., Square Inches, Square Millimeters, Square Centimeters) and convert between units.

Converting Fractional Inches to Decimal Inches

Convert 5-1/2 Inches to decimal Inches. Then convert back to Inch-Fractions.

KEYSTROKE	DISPLAY
On/C On/C	0.
5 Inch 1 / 2	5-1/2 INCH
Conv Inch	5.5 INCH
Conv Inch	5-1/2 INCH

Converting Inches to Centimeters, Millimeters

Convert 5-1/2 Inches to Centimeters. Then convert to Millimeters.

KEYSTROKE	DISPLAY
On/C On/C	0.
5 Inch 1 / 2	5-1/2 INCH
Conv cm	13.97 CM
Conv 9	139.7 MM

Area Conversions

Enter 100 Square Inches and convert to Centimeters and then Millimeters.

KEYSTROKE

DISPLAY

On/C	On/C		0.
1	0	0	100 SQ INCH
Conv	cm	Inch	645.16 SQ CM
Conv	9	Inch	64516. SQ MM

Note: You will notice in the above example, you maintain the area dimension when converting between Inches, Centimeters, and Millimeters. If you are converting from area values (e.g., Square Inches, Square Centimeters, or Square Millimeters) to linear values (e.g., Yardage and Meterage), the area values are converted to linear values based on the stored Fabric Width. If you attempt to convert back to Inches once the value has been converted to a linear value, it remains as a linear value and converts to Inches based on the value that resulted from the linear conversion to Yardage (or Meterage).

BASIC MATH

Adding Values

You are buying 2 Yards of green fabric, 3-1/2 Yards of red fabric, and 5-1/4 Yards of white fabric. What is the total fabric?

KEYSTROKE	DISPLAY
2 Ydg	2 YD
+ 3 Ydg 1 / 2	3-1/2 YD
+ 5 Ydg 1 / 4	5-1/4 YD
=	10-3/4 YD

Add 5-1/2 Yards to 10 Meters.

KEYSTROKE	DISPLAY
5 Ydg 1 / 2	5-1/2 YD
+ 1 0 m	10 M
=	16-1/2 YD

Subtracting Values

You have 8 Yards of fabric, but you only need 4-1/4 Yards to finish the blocks on your quilt. How much fabric will you have left?

KEYSTROKE	DISPLAY
8 Ydg	8 YD
- 4 Ydg 1 / 4	4-1/4 YD
=	3-3/4 YD

(Cont'd)

(Cont'd)

Subtract 32 Inches from 81 Inches.

KEYSTROKE	DISPLAY
8 1 Inch	81 INCH
− 3 2 Inch	32 INCH
=	49 INCH

Multiplying Values

Your fat quarter is 18" x 22". What is the area of this piece of fabric?

KEYSTROKE	DISPLAY
1 8 Inch × 2 2 Inch =	396. SQ INCH

Your quilt consists of ten different types of Squares from various fabrics, and each type of Square requires 2-1/2 Yards in order to make the squares. What is the total Yardage?

KEYSTROKE	DISPLAY
2 Ydg 1 / 2	2-1/2 YD
× 1 0	10
=	25 YD

Dividing Values

You have 1-1/2 Yards of material that you need to cut 7-Inch strips from. Divide 1-1/2 Yards by 7 Inches to calculate the number of strips to cut.

KEYSTROKE	DISPLAY
1 Ydg 1 / 2	1-1/2 YD
÷ 7 Inch	7 INCH
=	7.714286

(You will be able to cut seven 7-Inch strips)

You need to divide 10.5 Yards of fabric into five sections. Divide 10.5 Yards by 5:

KEYSTROKE	DISPLAY
1 0 • 5 Ydg	10.5 YD
÷ 5	5
=	2.1 YD
Conv / *	2-1/8 YD

You can also use the **/ to toggle between fractional and decimal displays.*

Percentage Calculations

The percent **%** key is used to find a given percent of a number or to perform add-on, discount or division percentage calculations. You may also perform percentage calculations with dimensional units (Yardage, Inch, etc.), in any format (Linear, Square, or Cubic).

Examples:

Find 5% of 15 Yards of material:

KEYSTROKE	DISPLAY
1 5 Ydg X 5 %	0-3/4 YD

Add 10% to 8 Yards of material:

KEYSTROKE	DISPLAY
8 Ydg + 1 0 %	8-7/8 YD

Subtract 20% from 120 Inches:

KEYSTROKE	DISPLAY
1 2 0 Inch - 2 0 %	96 INCH

Divide 200 Square Inches by 80%:

KEYSTROKE	DISPLAY
2 0 0 Inch Inch ÷ 8 0 %	250. SQ INCH

APPENDIX A – DEFAULT SETTINGS

After a Clear All (**Conv** **X**), your calculator will return to the following settings:

STORED VALUES	US MODE	METRIC MODE
Seam Width	1/4 Inch	.635 cm
Fabric Width	40 Inches	101.6 cm
Binding Cut Width	2-1/2 Inches	6.35 cm
Backing Overage (+)	4 Inches	10.16 cm

Note: The default values for Metric are equivalent to the US mode default values, but you may store any value for each of these items.

After a Full Reset (press **off**, hold down **X**, and press **On/C**), your calculator will return to the following settings (including those listed above for Clear All):

PREFERENCE SETTINGS	DEFAULT VALUE
Corner (Miter vs. Straight)	Mitered Corners
Sashing	Include Sashing Border
US/Metric Mode	US/Fractional Value

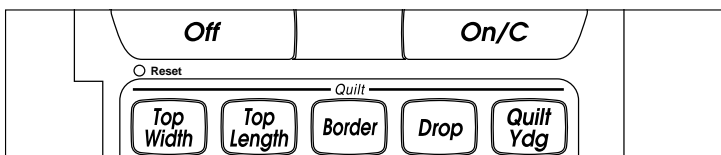

Reset Function

If your calculator should ever “lock up,” press Reset—a small hole located just below the **off** key—perform a total reset.



APPENDIX B – PREFERENCE SETTINGS

How to Set Preferences

Enter the Preference Setting Mode by pressing **Conv**  (*Prefs*). Access each category by pressing the  key until you reach the desired setting. *Within each category*, press the **+** or **-** keys to toggle between individual selections. Press **On/C** to exit and set your Preference.

Note: Press **+** to advance and press **-** to back up. Pressing the  key repeatedly in this mode will cycle through all of the Preferences.

You may change these settings at any time by repeating the above, and setting a new preference. Or, you may review settings by pressing **Rcl** .

To clear preferences and Reset the calculator, press the Reset button.

Accessing Preference Settings

To Select between Mitered or Straight Corners:

KEYSTROKE	DISPLAY
Conv  (<i>Prefs</i>)	Miter CornEr
+ (<i>plus sign</i>)	STRT CornEr
+ (<i>repeats options</i>)	Miter CornEr

Mitered Corner

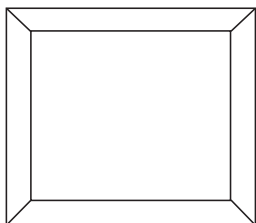

Straight Corner

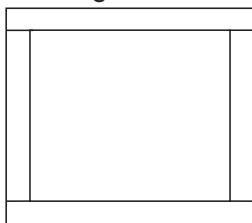

To Select between Sashing Border (Include or Exclude):

KEYSTROKE	DISPLAY
<input type="radio"/> (Prefs) – 2nd press of <input type="radio"/>	SASh+ bordEr
+ (plus sign)	SASh- bordEr
+ (repeats options)	SASh+ bordEr

Sashing + Border

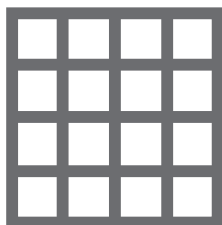

Sashing - Border

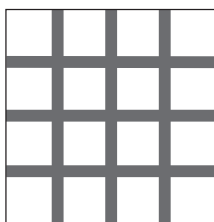

To Select Display Output of Fractions (US), Decimal (US), or Metric values:

KEYSTROKE	DISPLAY
<input type="radio"/> (Prefs) – 3rd press of <input type="radio"/>	FRAC UnitS
+ (plus sign)	DEC UnitS
+ *	METRC UnitS
+ (repeats options)	FRAC UnitS

Note: Press **On/C** at any time to exit the Preference Mode.

*When the Units Display Preference Setting is changed (e.g., from US unit display to Metric unit display), Seam, Fabric Width, Backing Overage, and Binding Cut values will remain unchanged until a Clear All (**Conv** **X**) is performed or new values are stored. User defined entries for these measurements will be maintained in the format in which they were stored when the US/Metric unit display preference setting is changed.

You may want to perform a Clear All when first setting your calculator to display in Metric units so that these values also display in Metric units to begin with. See Page 38 for a list of US and Metric default values.

APPENDIX C – IMPORTANT NOTES FOR OWNERS OF PREVIOUS FABRICALCS

If you are an owner of a previous Quilter's FabriCalc calculator, the following list will help you compare several enhanced features.

Quilt Ydg Function (Top/Backing)

The calculation for Top and Backing Yardage (part of the Quilt Yardage function) is now based on a linear, or “running” method, for layout out your quilt. This means the Length of each run is based on the Length of quilt, and the number of runs needed is based on the Width of the quilt. It is calculated this way to allow plenty of material to lay out your Top or Backing so that each run is uncut along the Length of the run (e.g., the strips run the Length of the quilt without having to piece material together).

Cost Function

The Cost function now bases it's calculation on the displayed (or entered) fractional value rather than the underlying decimal value (as in the previous version 1.0). In many cases, the fractional Yardage value has been rounded up to the nearest fraction. If you wish to calculate the Cost of material based on the actual decimal value that was calculated,

(Cont'd)

(Cont'd)

you may convert the displayed fractional value to the actual decimal value (for instance, **Conv** **Ydg** will convert the fractional Yardage to decimal Yardage) and use the decimal value to calculate the cost per Yard (or Meter).

Square Size Function

It is no longer necessary to press **Conv** **Square Size** to view the Square Diagonal.

Repeated presses of the **Square Size** button now toggle between the Square Size and the Square Diagonal.

Fractional Rounding

Decimal values can now be rounded to the nearest “Quilter’s” fraction by pressing **Conv** **/**. With a displayed decimal value (Yardage, Inch, or unitless value), pressing **Conv** **/** will convert this value to the nearest fractional value and modify the underlying decimal value to correlate with the displayed fractional value.

Yardage values will be rounded up to the closest fractional value if the decimal Yardage value exceeds the closest fractional equivalent by 0.01 Yard.

This feature is useful if you are working with or storing rounded, fractional values. The Quilter’s FabriCalc displays Yardage calculations in the closest fraction, even though the actual decimal value may not

(Cont'd)

(Cont'd)

match this rounded, fractional value. For instance, when calculating Yardage for 20 five-inch squares, the displayed fractional Yardage is $1/2$ Yard, even though the actual decimal value of this calculation is .45833 Yards. The Quilter's FabriCalc rounds up to the nearest fraction so that you purchase the proper amount of material in standard, fabric fractions.

When storing the displayed $1/2$ Yard in any of the memory registers (such as FAB-1), the actual decimal value is stored. The calculator will add the decimal values of any additional Yardages that are added to the cumulative memory registers, so the cumulative result will display to the nearest fraction based on the underlying decimal value.

For example, if you calculated $1/2$ Yard for 20 five-inch Squares and stored it in Fabric 1, and then calculated 40 five-inch Squares (result: 1 Yard) and added the resulting 1 Yard to Fabric 1, your total Fabric 1 result is $1-3/8$ Yards (not $1-1/2$ Yards) because the underlying decimal value is used. This helps you buy the correct quantity of material so you don't buy too much.

(Cont'd)

(Cont'd)

You can modify the decimal yardage value to match the displayed, rounded fractional Yardage value by pressing **Conv** **/**. In the example above, calculating Yardage for 20 five-Inch Squares and pressing **Conv** **/** would change the calculated decimal value (.45833) to match the displayed 1/2 Yard (.5).

APPENDIX D – OPERATING INSTRUCTIONS

Please follow the guidelines listed in this section for proper care and operation of your calculator. Not following the instructions listed below may result in damage not covered by your warranty. Refer to the **Repair and Return** section for more details.

Do not expose calculator to temperatures outside the operating temperature range of 32°F – 104°F (0°C – 40°C).

Do not expose calculator to high moisture such as submersion in water, heavy rain, etc.

BATTERY

Your calculator is powered by a single 3-Volt Lithium CR-2016 battery. This should last approximately 800 hours of actual use (1 year plus for most people). Should the display become very dim or erratic, replace the battery. **WARNING:** *Please use caution when disposing of your old batteries as they contain hazardous chemicals.*

Note: *Replacement batteries are available at most discount or electronic stores. You may also call Calculated Industries at 1-775-885-4900.*

Replacing the Battery

Turn the calculator over and open user guide door located at the top. Pull battery holder out (top left corner) and turn over. Remove old battery and slide new battery under tabs. Turn holder over (negative side facing you) and insert into calculator.



APPENDIX E – ACCURACY, ERRORS AND AUTO SHUT-OFF

Accuracy/Errors

Accuracy/Display Capacity – Your calculator has a seven digit display. You may enter or calculate values up to 9999999. Each calculation is carried out internally to twelve digits.

Your calculator is designed to calculate Yardage up to the nearest allowable fraction. In most cases, Yardage calculations will be displayed to the next available fraction so you calculate enough material (no shortages). Your calculator will, however, round down if the calculation is less than 0.01 to the nearest available fraction.

Fractional Inches are rounded to the nearest fraction.

Errors – When an incorrect entry is made, or the answer is beyond the range of the calculator, it will display the word “**ERROR.**” To clear an error condition you must press the **On/C** button once. At this point you must determine what caused the error and re-key the problem.

Error Codes

DISPLAY	ERROR TYPE
OFLO	Overflow (too large)
DIV Error	Divide by 0
DIM Error	Dimension error

DISPLAY	ERROR TYPE
ENT Error	Invalid entry error
TYP	Type error
FABRC Error	Fabric error*

* *Block or square height (with seam) exceeds fabric width*

Auto-Range – If an “overflow” is created because of an input and calculation with small units that are out of the standard seven digit range of the display, the answer will be automatically expressed in the next larger units (instead of showing “**ERROR**”) – e.g., 10,000,000 mm is shown as 10,000.00 m. Also applies to Inches and Yards.

Auto Shut-Off

Your calculator is designed to shut itself off after about 8-12 minutes of non-use.

APPENDIX F— REPAIR AND RETURN

WARRANTY, REPAIR AND RETURN INFORMATION

Return Guidelines

1. Please read the **Warranty** in this User's Guide to determine if your Calculated Industries product remains under warranty **before** calling or returning any device for evaluation or repairs.
2. If your product won't turn on, check the battery as outlined in the User's Guide.
3. If you need more assistance, please go to the website listed below.
4. If you believe you need to return your product, please call a Calculated Industries representative between the hours of 8:00am to 4:00pm Pacific Time for additional information and a Return Merchandise Authorization (RMA).

Call Toll Free: 1-800-854-8075

Outside USA: 1-775-885-4900

www.calculated.com/warranty

WARRANTY

Warranty Repair Service – U.S.A.

Calculated Industries (“CI”) warrants this product against defects in materials and workmanship for a period of one (1) year from the date of original consumer purchase in the U.S. If a defect exists during the warranty period, CI at its option will either repair (using new or remanufactured parts) or replace (with a new or remanufactured calculator) the product at no charge.

THE WARRANTY WILL NOT APPLY TO THE PRODUCT IF IT HAS BEEN DAMAGED BY MISUSE, ALTERATION, ACCIDENT, IMPROPER HANDLING OR OPERATION, OR IF UNAUTHORIZED REPAIRS ARE ATTEMPTED OR MADE. SOME EXAMPLES OF DAMAGES NOT COVERED BY WARRANTY INCLUDE, BUT ARE NOT LIMITED TO, BATTERY LEAKAGE, BENDING, A BLACK “INK SPOT” OR VISIBLE CRACKING OF THE LCD, WHICH ARE PRESUMED TO BE DAMAGES RESULTING FROM MISUSE OR ABUSE.

To obtain warranty service in the U.S., please go to the website.

A repaired or replacement product assumes the remaining warranty of the original product or 90 days, whichever is longer.

Non-Warranty Repair Service – U.S.A.

Non-warranty repair covers service beyond the warranty period, or service requested due to damage resulting from misuse or abuse.

Contact Calculated Industries at the number listed on the last page of this guide to obtain current product repair information and charges. Repairs are guaranteed for 90 days.

Repair Service – Outside the U.S.A.

To obtain warranty or non-warranty repair service for goods purchased outside the U.S., contact the dealer through which you initially purchased the product. If you cannot reasonably have the product repaired in your area, you may contact CI to obtain current product repair information and charges, including freight and duties.

Disclaimer

CI MAKES NO WARRANTY OR REPRESENTATION, EITHER EXPRESS OR IMPLIED, WITH RESPECT TO THE PRODUCT'S QUALITY, PERFORMANCE, MERCHANTABILITY, OR FITNESS FOR A PARTICULAR PURPOSE. AS A RESULT, THIS PRODUCT, INCLUDING BUT NOT LIMITED TO, KEYSTROKE PROCEDURES, MATHEMATICAL ACCURACY AND PREPROGRAMMED MATERIAL, IS SOLD "AS IS," AND YOU THE PURCHASER ASSUME THE ENTIRE RISK AS TO ITS QUALITY AND PERFORMANCE.

IN NO EVENT WILL CI BE LIABLE FOR DIRECT, INDIRECT, SPECIAL, INCIDENTAL, OR CONSEQUENTIAL DAMAGES RESULTING FROM ANY DEFECT IN THE PRODUCT OR ITS DOCUMENTATION.

The warranty, disclaimer, and remedies set forth above are exclusive and replace all others, oral or written, expressed or implied. No CI dealer, agent, or employee is authorized to make any modification, extension, or addition to this warranty.

Some states do not allow the exclusion or limitation of implied warranties or liability for incidental or consequential damages, so the above limitation or exclusion may not apply to you. This warranty gives you specific rights, and you may also have other rights, which vary from state to state.

FCC Class B

This equipment has been certified to comply with the limits for a Class B computing device, pursuant to Subpart J of Part 15 of FCC rules.

Looking For New Ideas

Calculated Industries, a leading manufacturer of special-function calculators and digital measuring instruments, is always looking for new product ideas in these areas.

If you have an idea, or a suggestion for improving this product or User's Guide, please submit your comments online at www.calculated.com under "Contact Us", "Product Idea Submittal Agreement". Thank you.

INDEX

- Accuracy/Errors, 64
- Auto Shut-Off, 65
- Basic Math with Dimensions, 51
- Basic Operation Keys, 1
- Battery, Replacing, 62
- Blocks, 22, 26, 28, 30
- Conversions, Unit, 49
- Converting Fractional Inches to Decimal Inches, 49, 59
- Corner Triangles, 40
- Cost, of Material, 48, 58
- DEFAULT SETTINGS, 55
- Diamonds, 45° and 60°, 33
- Dimensional Measurement Unit Keys, 6
- Dimensions (Linear), Entering, 6
- Dimensions, Adding, 51
- Dimensions, Dividing, 53
- Dimensions, Multiplying, 52
- Dimensions, Subtracting, 51
- Error Codes, 64
- Half Square Triangles, 32, 40, 41
- Memory Operation, 46
- Multiple Borders, 17
- Percentage Calculations, 54
- PREFERENCE SETTINGS, APPENDIX B, 56
- Quarter Square Triangles, 33, 41
- Quilt Sizes, 13
- Quilt, Yardage, 9
- Repair and Return, 66
- Reset Key, 55
- Sashing, 24, 26
- Side Triangles, 40, 41
- Squares, 31, 35, 37, 39, 59
- Warranty, 67
- Yardage, 4, 58, 59



**CALCULATED
INDUSTRIES®**

Putting answers at your fingertips since 1978

This equipment has been certified to comply with the limits for a Class B computing device, pursuant to Subpart J of Part 15 of FCC rules.

Software copyrighted and licensed to
Calculated Industries, Inc. by
Specialty Calculator Technologies, LLC, 2005.

Pocket Reference Guide copyrighted by
Calculated Industries, Inc. © 2005.

FabriCalc™ is a trademark and
Calculated Industries® is a registered trademark
of Calculated Industries, Inc.

ALL RIGHTS RESERVED

CALCULATED INDUSTRIES®

Available at:

JUBILEE ROSE ENTERPRISES LTD.

Tel: (604) 535-7339

Fax: (604) 535-7691

Email: sales@jubileerose.com

Website: www.jubileerose.com

Designed in the U.S.A.

Printed in China

Patent Pending

Model 8400 v1.1

UG8400E-C